

INNOVATIVE REUSE TREATMENT TECHNOLOGY REFERENCE GUIDE



The power of purple.
We think it's
perfectly natural.

Introduction

Welcome to some of the bright new ideas that can be found at Carollo Engineers. Our engineers and researchers strive to find the latest cost-effective and proven technologies for our clients. This critical research by Carollo, funded by organizations such as WaterReuse Foundation, the Water Environment Research Foundation, the Water Research Foundation, and various industrial partners, focuses on higher energy efficiency, lower capital cost, and more sustainable reclaimed water treatment technologies.

Within this booklet you will find:

- Sustainable technologies for indirect potable reuse (IPR)
- The sustainable use of pasteurization for disinfection
- The application of ozone for combined disinfection/EDC destruction
- New research on removing EDCs during secondary treatment
- The latest findings on innovative tertiary treatment technologies
- The next generation of advanced oxidation technologies
- Effective high rate filtration with three times the conventional flux
- Ways to minimize RO brine and chemical use
- Working to reduce aquatic impacts to sensitive species in Utah
- New findings on advanced membrane treatment and aquatic impacts from surface water augmentation
- The cost and value of small scale and satellite reclamation facilities
- The latest UV reactors for efficient disinfection and dose control
- Using CFD to optimize UV hydraulics and reduce costs
- How to commission and optimize existing UV systems

The projects reviewed here, as well as many others, can be found in detail in Carollo's Research Solutions publications.

photo here?

Metric Tons of Carbon Dioxide Equivalent Emissions per Million Gallons of Treated Wastewater Resulting from O&M of Tertiary Treatment Facilities

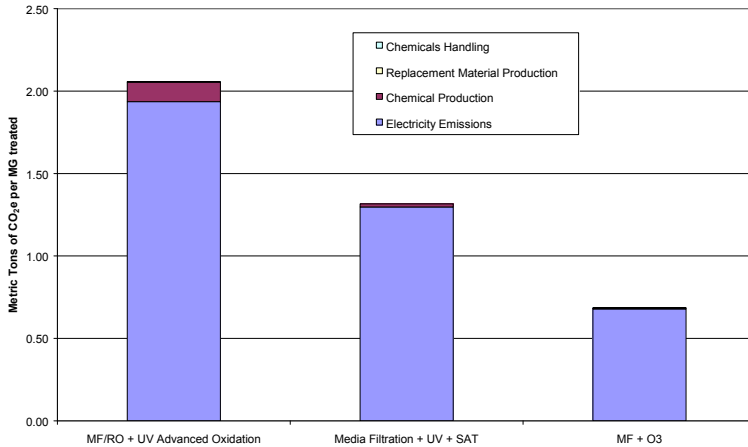

Carollo Carbon Footprint Analysis for Various IPR Technologies

"The continued security and economic health of the United States depends on a **sustainable** supply of both energy and water."



Sustainable Options for Indirect Potable Reuse (IPR)

IPR means different things to different people. Public groups can see it as a community health issue (e.g. Toilet to Tap), where municipalities see it as a proven, effective treatment solution for their reuse needs. The current treatment model, utilizing advanced membrane and oxidation technologies, is well accepted both nationally and globally. However, this treatment model which is being copied throughout the United States, Australia, and now Asia comes at an extremely high financial and environmental cost.

More sustainable IPR technologies exist, all proven to protect public health while preserving economic resources and minimizing carbon footprint. These alternative IPR technologies include less costly membrane and oxidation technologies and engineered treatment enhanced by natural systems, as evidenced by recent Carollo investigations pictured here.

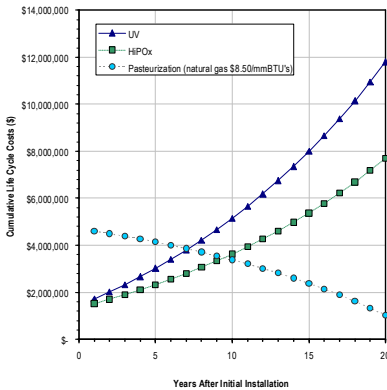

Sustainable Use of Waste Heat Means Low Cost Disinfection

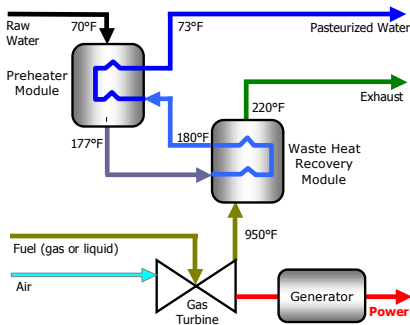

Pasteurization is Title 22 Approved

Pasteurization is the Sustainable Solution for Disinfection

Standard technologies available for reclaimed water disinfection are energy intensive, either during the production and transportation phase (such as sodium hypochlorite) or during the treatment phase (such as UV or ozone). One recent technology, pasteurization, has emerged as a truly sustainable option. Pasteurization has been around since the 1860s, but this simple treatment process, originally developed to disinfect beer, wine, and ultimately milk, has now been validated and approved by regulators for reuse water disinfection. The economy of pasteurization is based upon the capture of a waste heat source (turbine exhaust, solar heat, and cooling towers, as several examples) and the transfer of that heat to the water for disinfection.

Economic analysis by Carollo for clients nationwide (South Florida Water Management District, Daly City, Kansas City, Ventura) have shown pasteurization to be the lowest cost system, both in energy use and total cost.

This low-cost, low-energy technology is now being constructed on a large scale (0.5 MGD) for long-term performance demonstration. If your treatment plant is looking for energy and disinfection solutions, make Pasteurization the sustainable disinfection technology for your community.



The HiPOx™ ozone system is Title 22 Approved

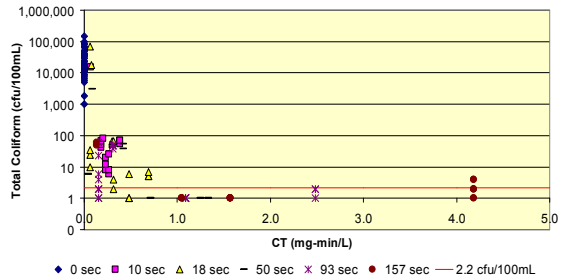

Detailed Research by Carollo Determined Proper Ozone CT Values for Reuse

Ozone Disinfection is Approved for Reuse

Carollo researchers recently completed the most extensive investigation of ozone disinfection ever undertaken. The result? Title 22 approval of ozone disinfection from the California Department of Public Health, and encouraging economic models that put ozone on a financial level with UV.

If your treatment challenges include pharmaceuticals, EDCs, and other difficult to remove constituents, ozone may be your solution!

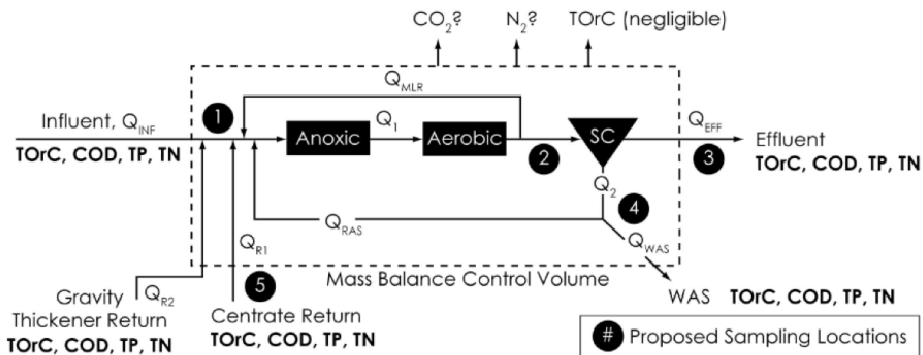

Sample WWTP Testing Plan for WERF CEC4R08 Trace Organic Compounds (TOxC) Project

Get Rid of EDCs Through Proven Secondary Treatment Methods

As public concern grows regarding pharmaceuticals, potential endocrine disrupting compounds (EDCs), and other trace organic contaminants, public agencies rely on advanced engineering research to help them achieve customer confidence at an affordable cost.

While tertiary treatment (such as membranes and oxidation) provide protection, they come at a high price. Instead, advances in secondary treatment optimization are helping efficiently and cost-effectively reduce these trace organic compounds, while reducing the costs involved with expensive additional treatment processes. Carollo's ongoing WERF project can help your agency take control of EDC reduction while maximizing the value of processes you already operate!



UV/PAA Pilot in Florida



TiO₂/UV Pilot in North Carolina



Ozone Pilot in California

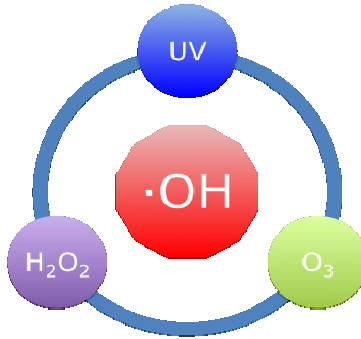

UV/Peroxide Pilot in Florida

Project WRF 02-009 funded by the WaterReuse Foundation and the Southwest Florida Water Management District

The Lowest Cost Pathogen/EDC Destruction System Has Been Found

What's the best disinfection method for reuse water? Where chlorine was once the ultimate "go to" disinfection method, the challenges of DBPs and NDMA formation demand a better answer. Today, Carollo researchers, working with the USDA and Duke University, are looking at new technologies, such as peracetic acid (PAA), titanium dioxide with UV, ozone, and other technologies to destroy pathogens and trace compounds in reuse water.

The ultimate solution depends on your constituents of concern, but there are affordable, effective disinfection technologies in place right now, and an optimized disinfection evaluation can help your agency find solutions for long-term, cost-conscious reuse water treatment.



AquaPure Pilot in California

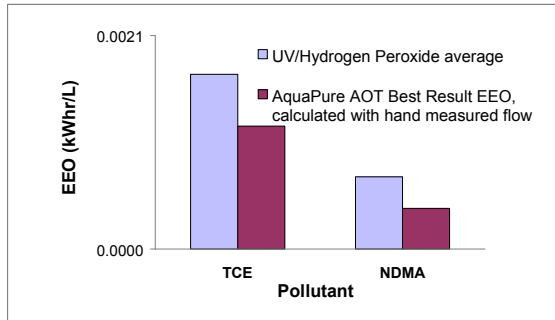

Plasma and Radicals Within the AquaPure Reactor

AquaPure's Hydro-Non-Thermal Plasma System Outperforms Conventional Advanced Oxidation Treatment

New More Efficient Advanced Oxidation Destroys Trace Organic Compounds

Public and regulatory concerns demand better technologies to destroy trace compounds in reuse water. Advanced oxidation (UV disinfection coupled with hydrogen peroxide) or ozone, are effective, but costly and not efficient for a full range of target compounds.

Recent pilot testing of the AquaPure Hydro-Non-Thermal Plasma System by Carollo, tested side by side with conventional UV/H₂O₂ treatment, showed superior NDMA and trace compound removal and at a more attractive operational cost. Having a single technology to destroy trace compounds and NDMA has been a long-sought goal and the AquaPure system may be the solution the industry has been waiting for.



Nova Ultrascreen[®] Disc Filtration

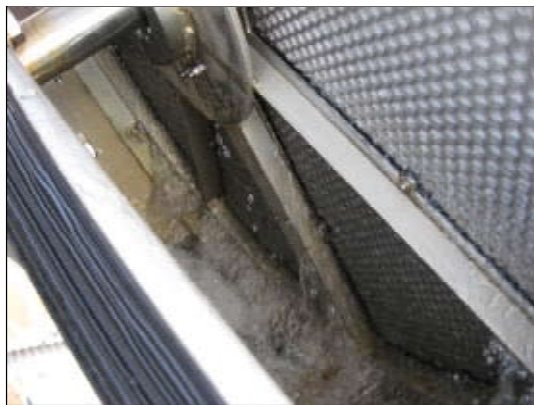

Tangential Filtration Allows Operation at >3 Times Conventional Filtration Rates!

High-Rate Filtration for Reuse? Yes!

Filtration flux plays a critical role in the performance and cost of tertiary filtration technologies, with low fluxes resulting in the best treatment but the highest cost.

But there's another option. Carollo pilot testing of the Nova Ultrascreen Disc Filter has recently been shown to provide effective filtration performance at a flux of 16 gpm/ft², triple the rate of conventional flux values! At this high flux level, the costs for tertiary filtration are not only attractive, but could change the industry's perception of the value of high-rate filtration for reuse water.



Carollo and the City of Phoenix Attain 95% Recovery on Brackish Water



Chemical Pretreatment and Pellet Softening Reduces Chemical Use and Residuals

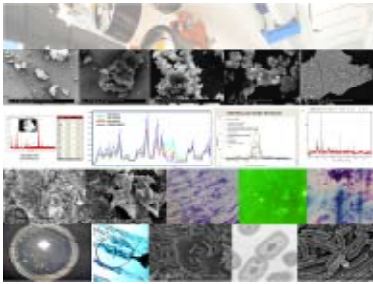

Analytical Tools Allow for Rapid Characterization of Membrane Fouling Potential

Carollo is Improving RO Recovery and Reducing Chemical Use

Carollo is advancing the ongoing research funded by the City of Phoenix for concentrate volume minimization studies using conventional softening by studying a fluidized bed pellet softening process. Treatment costs, chemical usage, residuals handling, and energy consumption will be compared between the conventional softening and pellet softening process as part of this Water Research Tailored Collaboration project. Results from the pilot studies will provide a reference for desalination planners who are considering implementing concentrate volume reduction technologies.

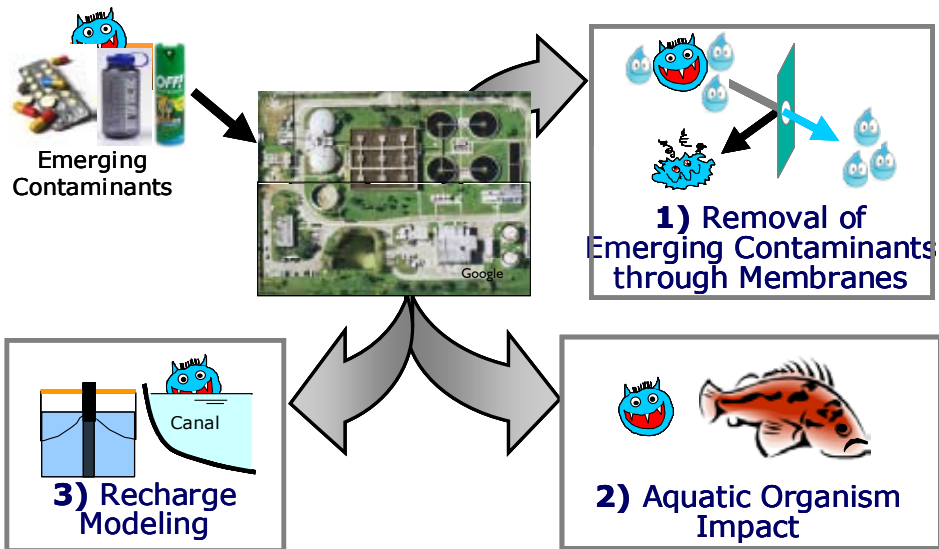

Project WRF 06-019 funded by the WaterReuse Foundation and the South Florida Water Management District

Removing Microconstituents and Reducing Aquatic Impacts with Membranes

Reuse water has a variety of destinations, ranging from landscape irrigation, to agricultural use, to aquifer recharge, to surface water augmentation. With increased regulatory focus on eliminating microconstituents (including trace pharmaceuticals and endocrine disrupting compounds) from the environment and public water supplies, membrane treatment is finding a new role to play in our nation's water supply.

The WaterReuse Foundation and the South Florida Water Management District funded Carollo to lead a detailed research project to evaluate the ability of various membrane treatment systems to reduce microconstituents and the related aquatic impacts as part of surface water augmentation. Results show correlate specific levels of treatment and hormonal reduction to a reduction in aquatic impact. Surprising results also demonstrate an increase in toxicity due to some common treatment methods.

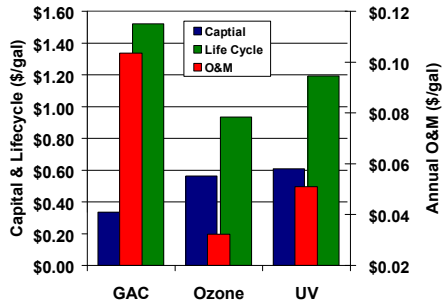
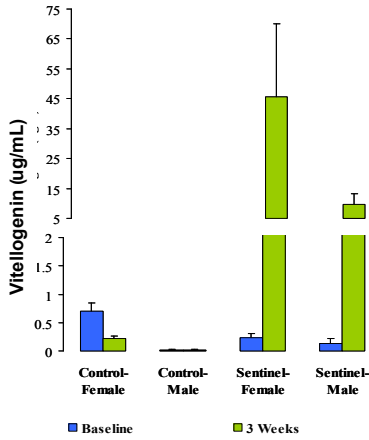

Ozone is the Lowest Cost Treatment to Reduce EDCs

Pre and Post Wastewater Exposure Trout Blood Plasma Sample Comparison

Carollo and the Snyderville Basin Water Reclamation District are Studying the Wastewater Impact to Sensitive Trout Species in Utah

Aquatic organisms such as trout have been shown to be highly sensitive to estrogenic activity in wastewater treatment plant effluent. Estrogenic impacts from effluent may include effects such as vitellogenesis in male fish, feminization of the population towards a great number of females, intersex fish, or even population collapse. Recent work by Carollo and the Snyderville Basin Water Reclamation District (SBWRD) in Park City, Utah looked at the actual impact from the SBWRD effluent and the costs for advanced treatment to remove potential endocrine disrupting compounds.

The conclusions were significant. As the East Canyon Creek treatment plant leads to an effluent dominated stream during the summer months, male trout were held in SBWRD effluent for three weeks. After exposure, the male trout began producing the female egg yolk protein vitellogenin, though at low levels. Other encouraging results were found, as the sex-ratio of the downstream trout populations was not found to be skewed towards a greater number of females based on the results of a field investigation.

Potential treatment modifications were also examined. Pilot and bench scale testing on SBWRD effluent showed that GAC sorption, Ozone (AOP) and UV (AOP) reduced estrogenic activity. Ozone (AOP) was recommended based on a lifecycle cost analysis. 2009 WATEREUSE SYMPOSIUM · SEATTLE | 12



Costs and
Performance of
Small Scale WRPs,
from 0.1 to 1.0
MGD, documented
by Carollo

Project WRF 06-008 funded by the WaterReuse Foundation

Low Cost Satellite and Small-Scale Treatment Solutions

While membrane bioreactors are often the technology of choice for small-scale reclamation systems, rural communities often don't have the engineering or operations staff experienced with advanced membrane treatment. In addition, MBR quality effluent is often much higher than required, wasting money with little benefit.

A recent WaterReuse-funded study, ran by Carollo Engineers and Humboldt State University, took on the challenge of identifying established and innovative small-scale technologies that would provide economical and reliable reclaimed water treatment for a variety of municipal and public needs. If small-scale or satellite reclamation is in your future, the study, entitled, Low Cost Treatment Technologies for Small-Scale Water Reclamation Plants, is a good place to start!



Calgon C³500 in Stockton CA



WEDECO TAK-55 in San Jose CA



UVFIT in Ontario Canada



Testing in Accordance with NWRI



Aquionics InLine in Portland OR



The latest microwave UV system (coming soon)

***Reactors Certified by Carollo Within the Last 12 Months**

New UV Reactor Research Increases Disinfection Efficiency

UV has proven to be a robust disinfectant. But with the wide variety of UV options out there, an agency's greatest challenge is determine what technology best fits their disinfection needs.

Understanding reactor performance is key to identifying your agency's perfect UV solution. Working with State regulators, Carollo leads the industry in independent third-party evaluations of UV technologies. This unparalleled experience helps our clients make the right decision about their UV needs, and avoid wasting time, energy, and money on the wrong system.

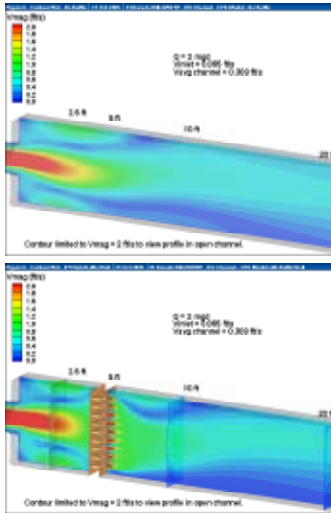

Diffuser Plates Improve Hydraulics

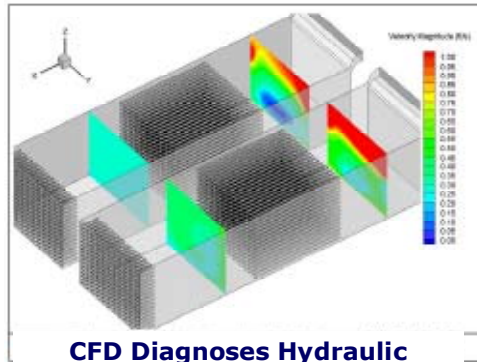

CFD for UV Reduces Costs by Optimizing Channel Design and Hydraulics

UV designs rely upon equal flow split and uniform hydraulic approach. Too numerous examples abound of UV systems shoe-horned into tight spaces with a resulting drop in capacity and efficiency.

Carollo UV designs depend upon accurate computational fluid dynamic (CFD) models to optimize hydraulics, improve disinfection capacity, and reduce construction cost. We use these CFD models for both open-channel and in-vessel UV system designs and for troubleshooting and optimizing already constructed systems



Reducing Energy Use by 30% in Livermore CA

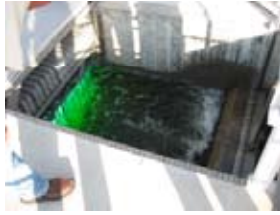

Doubling Capacity in Escondido CA



Commissioning in Watsonville CA



Testing in Accordance with NWRI



Commissioning DSRSD CA



Commissioning 2 Reactors in Lancaster CA

Commissioning and Optimizing Existing UV Reactors

Simply installing a UV system isn't enough. Commissioning UV reactors can be a real challenge. Once installed, opportunities exist to optimize reactor efficiency to make sure you maximize the value of your disinfection system while minimizing your operations costs.

If your UV reactor needs commissioning, has hydraulic problems, uses excessive energy, or fails to meet your disinfection needs, solutions are available to help your agency get the most from your disinfection dollar!

Title

MAP